

BISSETT^{TM/MC}

DRIVEN BY PROFESSIONALS

OIL-FREE AIR COMPRESSOR

BC-4GTWIN



USER MANUAL



TABLE OF CONTENTS

Introduction

- 4 Using the Operator's Manual

Product Identification

- 5 Record Identification Numbers

Safety

- 6 Receipt and Inspection
- 7 Description
- 8 Safety Instructions
- 8 Hazard Symbols and Meanings
- 9 Warnings

Installation & Grounding

- 12 Installation & Grounding Instructions
- 13 Extension Cords

Assembly

- 14 BC-4GTWIN

Maintenance

- 15 Draining the Air Tank and Changing the Air Filter
- 16 Adjusting the Pressure Switch

Storage

- 17 Procedure

Troubleshooting

- 18 Troubleshooting Chart

Unit Breakdown

- 19 Unit Breakdown & Reference List

Warranty

- 22 Warranty

INTRODUCTION



Attention: Read through the complete manual prior to the initial use of your compressor.

Using the Operator's manual

Please take time to read through this manual so you better understand the machine's operation, maintenance and safety precautions.

Everyone who operates this machine must read and understand this manual. The time you take now will prolong your machine's life and prepare you for its safe operation.

The manufacturer reserves the right to make improvements in design and/or changes in specifications at any time without incurring any obligation to install them on units previously sold.

PRODUCT IDENTIFICATION

Record Identification Numbers

Compressor

If you need to contact an Authorized Dealer or Customer Service line (604-545-0252) for information on servicing, always provide the product model and identification numbers.

You will need to locate the model and serial number for the machine and record the information in the places provided below.

Date of Purchase:
Dealer Name:
Dealer Phone:

Product Identification Numbers

Model Number:
Serial Number:

Specifications

Model	BC-4GTWIN
Cut-in Pressure	105 PSI
Cut-out Pressure	135 PSI
Tank Size	4 GALLON
Rated Voltage / Frequency	120V/60Hz
Current	14A

SAFETY

Receipt and Inspection

Before signing the delivery receipt, inspect for damage and missing parts. If damage or missing parts are apparent, make the appropriate notation on the delivery receipt, then sign the receipt. Immediately contact the carrier for an inspection. All materials must be held in the receiving location for the carrier's inspection. Delivery receipts that have been signed without a notation of damage or missing parts are considered to be delivered "clear". Subsequent claims are then considered to be concealed damage claims. Settle damage claims directly with the transportation company.

If you discover damage after receiving the air compressor (concealed damage), the carrier must be notified within 15 days of receipt and an inspection must be requested by telephone with confirmation in writing. On concealed damage claims, the burden of establishing that the compressor was damaged in transit reverts back to the claimant. Read the compressor nameplate to verify it is the model ordered, and read the motor nameplate to verify it is compatible with your electrical conditions. Make sure electrical enclosures and components are appropriate.

Save these Instructions

SAFETY RULES



This is the safety alert symbol. It is used to alert you to potential personal injury hazards. Obey all safety messages that follow this symbol to avoid possible injury or death.

The safety alert symbol (▲) is used with a signal word (DANGER, CAUTION, WARNING), a pictorial and/or a safety message to alert you to hazards.

DANGER: WILL cause DEATH, SEVERE INJURY or substantial property damage.

WARNING: CAN cause DEATH, SEVERE INJURY or substantial property damage.

CAUTION: WILL or CAN cause MINOR INJURY or property damage.

NOTICE: indicates a situation that could result in equipment damage. Follow safety messages to avoid or reduce the risk of injury or death.

Hazard Symbols and Meanings

EXPLOSION	FIRE	ELECTRIC SHOCK	TOXIC FUMES
KICKBACK	HOT SURFACE	WEAR EYE PROTECTION	SLIPPERY
FALL	FLUID INJECTION	MOVING PARTS	READ MANUAL

SAFETY

WARNING



AIR TANK WARNING: Drain liquid from air tank daily, or after each use, using the drain valve located on the bottom of the lower air tank. Failure to properly drain liquid from the tank will cause rust from moisture buildup, which weakens the tank and could lead to a violent tank explosion. Periodically inspect the tanks for unsafe conditions such as corrosion.

Never attempt to repair or make modifications to the tank or its attachments. Welding, drilling or any other modifications may weaken the tank, which may result in damage from rupture or explosion. Never remove or attempt to adjust the pressure switch, safety valve, or other factory set operating pressures.

WARNING



FIRE WARNING: Avoid dangerous environments. Do not use compressor near gasoline or other flammable materials. Keep work area well lit. Normal sparking of a motor or sparking from grinding metal could ignite fumes. Do not spray flammable materials in the vicinity of an open flame or other ignition source, including the air compressor itself. Do not direct paint or other spray material towards the compressor.



Read and follow all safety instructions for the material you are spraying. Be sure to use an approved respirator designed for use with your specific application.

WARNING







BREATHABLE AIR WARNING: This air compressor is not designed, nor intended for the supply of breathable air. Air produced by this unit may contain carbon monoxide or other toxic vapors.

Do not inhale air from the compressor or from a breathing device connected to it.

 WARNING	
	ELECTRIC SHOCK WARNING: When using electric powered tools, machines or equipment, basic safety precautions should always be followed to minimize the risk of electrical shock or personal injury to yourself and others.
This air compressor is powered by electricity and should never be used without properly grounded electrical connections. Do not use in wet or damp locations or expose to rain.	

 WARNING	
	AIR TOOLS AND ACCESSORIES WARNING: Do not exceed the pressure rating of any air tools, spray guns, air accessories, or inflatables. Excess pressure can cause them to explode, resulting in serious injury. Follow the manufacturers recommended pressure settings for all air tools and air accessories.

 WARNING	
	Do not direct compressed air stream at people or pets. The powerful compressed air stream can damage exposed skin and easily propel loose dirt and other small objects. Always wear eye protection that meets ANSI Z28.1 specifications.

 WARNING	
	Keep hands and fingers away from exposed metal parts on a running air compressor. Air compressors generate significant heat during normal operation, which can cause serious burns. The compressor will remain hot for some time after operation and should not be touched or moved until cool.

	WARNING ADVERTENCIA • AVERTISSEMENT
Cancer and Reproductive Harm Cáncer y Daño Reproductivo Cancer et dommages à la reproduction	
www.P65Warnings.ca.gov	



SAFETY



GENERAL SAFETY INFORMATION

Do not operate unit if damaged during shipping, handling, or use. Damage may result in bursting and cause injury or property damage.

Since the air compressor and other components (filters, lubricators, hoses, etc.) used make up a high pressure pumping system, the following safety precautions must be followed at all times:

1. Read all manuals included with this product carefully. Be thoroughly familiar with the controls and the proper use of the equipment.
2. Follow all local electrical and safety codes.
3. Only persons well acquainted with these rules of safe operation should be allowed to use the compressor.
4. Keep visitors away and NEVER allow children in the work area.
5. Wear safety glasses and use hearing protection when operating the pump or unit.
6. Do not stand on or use the pump or unit as a handhold.
7. Before each use, inspect compressed air system and electrical components for signs of damage, deterioration, weakness or leakage. Repair or replace defective items before using.

 WARNING	
	Motors, electrical equipment and controls can cause electrical arcs that will ignite a flammable gas or vapor. Never operate or repair in or near a flammable gas or vapor. Never store flammable liquids or gases in the vicinity of the compressor.



 WARNING	
	Compressor parts may be hot even if the unit is stopped.

8. Check all fasteners at frequent intervals for proper tightness.
9. Keep fingers away from a running compressor; fast moving and hot parts will cause injury and/or burns.
10. If the equipment should start to abnormally vibrate, STOP the engine/motor and check immediately for the cause. Vibration is generally a sign of trouble or a flaw within the machine.
11. To reduce fire hazards, keep engine/motor exterior free of oil, solvent, or excessive grease. Never remove or attempt to adjust safety valve. Keep safety valve free from paint and other accumulations.

12. Never attempt to repair or modify a tank! Welding, drilling or any other modification will weaken the tank, resulting in damage from rupture or explosion. Always replace worn or damaged tanks. Drain liquid from tank daily.
13. Tanks rust from moisture build-up, which weakens the tank. Make sure to drain tank daily and inspect periodically for unsafe conditions such as rust formation and corrosion.
14. Fast moving air will stir up dust and debris which may be harmful. Release air slowly when draining moisture or depressurizing the compressor system.



SPRAYING PRECAUTIONS

15. Do not smoke when spraying paint, insecticides, or other flammable substances.
16. Use a face mask/respirator when spraying and spray in a well ventilated area to prevent health and fire hazards.
17. Do not direct paint or other sprayed material at the compressor. Place the compressor as far away from the spraying area as possible to minimize over-spray accumulation on the compressor.
18. When spraying or cleaning with solvents or toxic chemicals, follow the instructions provided by the chemical manufacturer.

 WARNING	
	Do not spray flammable materials in vicinity of open flame or near ignition sources including the compressor unit.

HOSE PRECAUTIONS

19. Inspect hose before use. Do not exceed working pressure marked on hose. Do not twist, bend knot, or abrade hose. Do not wrap hose around body.
20. Keep away from hot surfaces and chemicals.

 WARNING	
	Arcing Parts. Keep the compressor/motor at least 6m away from explosive vapor.



INSTALLATION & GROUNDING

INSTALLATION AND LOCATION

The compressor must be used on a stable and level surface. It must also be used in a clean and well-ventilated area. The compressor requires an unobstructed airflow and must be placed a minimum of 18 inches from any walls or other obstructions.

GROUNDING INSTRUCTIONS

This product should be grounded. In the event of an electrical short circuit, grounding reduces the risk of electric shock by providing an escape wire for the electric current. This product is equipped with a cord that contains a grounding wire and an appropriate grounding plug. The plug must be plugged into an outlet that is properly installed and grounded in accordance with all local codes and regulations.

 DANGER	
	ELECTRIC SHOCK: Improper installation of the grounding plug can result in a risk of electric shock. If repair or replacement of the cord is necessary, do not connect the grounding wire to either flat blade terminal. The wire with an outer surface that is green with or without yellow stripes is the grounding wire.

This product is for use on a nominal 120-volt circuit and has a three-prong grounding plug that looks like the plug illustrated in Figure 1. Make sure that the product is connected to an outlet with the same configuration as the plug. No adapter should be used with this product.

The use of a GFCI outlet is strongly recommended. The third prong is to be used ground to the tool and provide protection against electrical shock. Never remove the third prong.

Check with a qualified electrician or serviceman if the grounding instructions are not completely understood, or if in doubt as to whether the product is properly grounded. Do not modify the plug provided; if it will not fit the outlet, have the proper outlet installed by a qualified electrician.

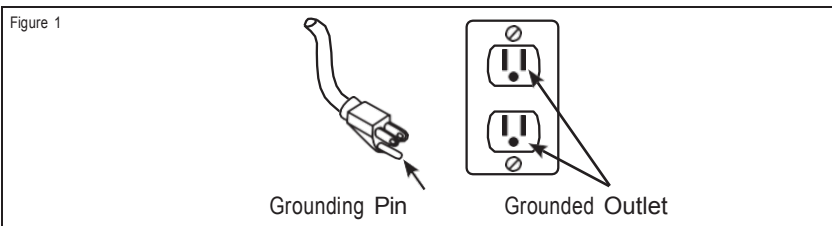

INSTALLATION & GROUNDING

EXTENSION CORDS

We do not recommend the use on an extension cord with this product as this may result in the loss of power and overheating of the motor. An additional air hose should be used instead of an extension cord. However, if the use of an extension cord is unavoidable, use only UL listed wire extension cords that have three-pronged grounding type plugs and three prong receptacles that accept the tool's plug. Improper use of extension cords may cause inefficient operation of your compressor, which can result in overheating.

Be sure your extension cord is rated to allow sufficient flow to motor. Refer to the guide for minimum gauge required for extension cords.

Extension Cord Length	Wire Size (A.W.C.)
Up to 25 Feet	14
26 to 50 Feet	12
51 to 100 Feet	10

Use of an extension cord heavy enough to carry the current the tool will draw is very important. Especially when the power source is of great distance. An extension cord that is insufficient will cause a drop in line voltage, resulting in power loss and causing the motor to overheat.

Guard against electrical shock. Avoid body contact with grounded surfaces such as pipes, radiators, ovens, stoves, and refrigerator enclosures. If not properly grounded, this power tool can incur the potential hazard of electrical shock, particularly when used in damp locations. If an electrical shock occurs, there is the potential of a secondary hazard such as your hands contacting an operating air tool.

ASSEMBLY

BC-4GTWIN

CONTENTS

- 1. Air compressor
- 2. Operation manual
- 3. Air filter

ASSEMBLY

Attach the air filter to the top right side of motor head.
Screw air filter into the motor head.

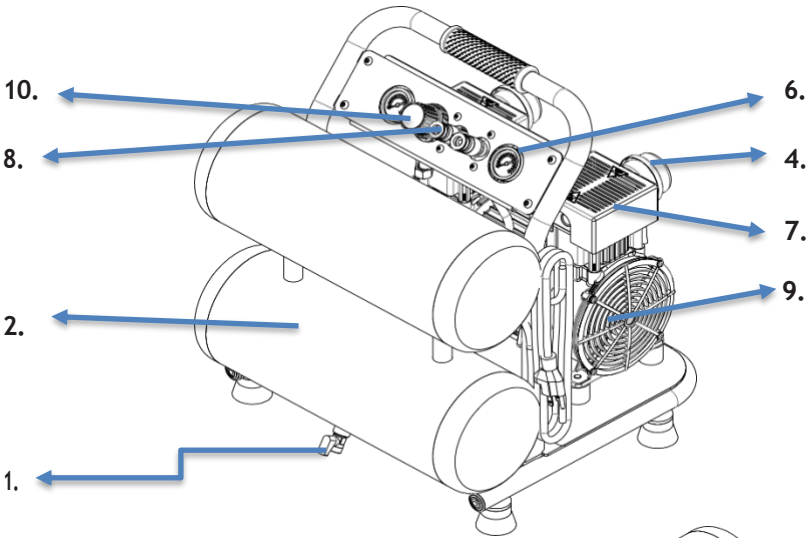

- 1. Tank Drain
- 2. Air Tank
- 3. Safety Relief Valve
- 4. Air Filter
- 5. Pressure Switch
- 6. Pressure Gauge (2)
- 7. Pump head (2)
- 8. Air Coupler (2)
- 9. Cooling Fan Head (2)
- 10. Regulator

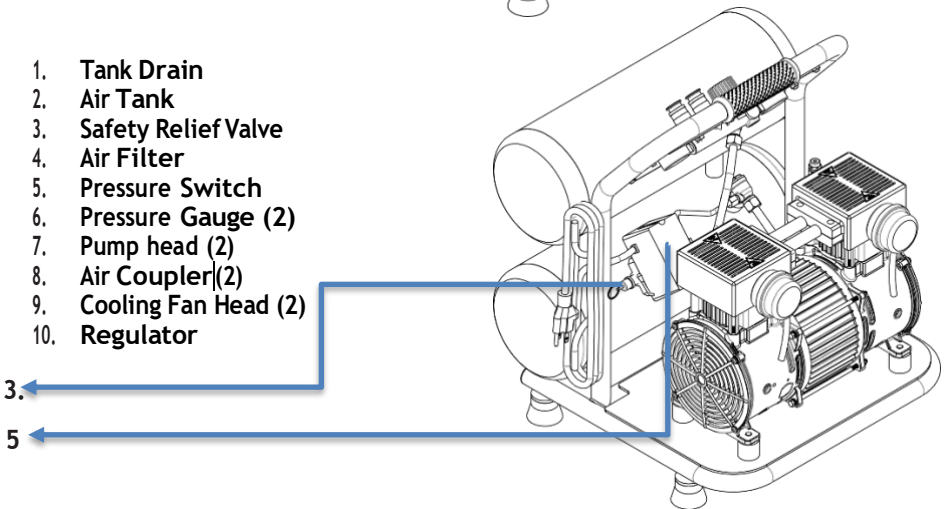

DRAINING THE TANK

The frequency at which you should drain the air tank depends on the environmental conditions and the amount of operating time logged. The average draining frequency is every 2 to 3 days.

1. Place the air compressor above a container capable of holding water.
2. With compressed air in the tank, slowly turn the drain valve knob counterclockwise. The water in the air tank will drain out.
3. After all of the accumulated water has drained out, turn the drain valve knob clockwise until it is tight, in order to avoid leakage.

CHANGING THE AIR FILTER

The air filter is designed to reduce noise and help prevent particulates in the air from entering and damaging the air compressor.

After being used for a period of time, the air filter will become clogged. This will reduce the air intake capabilities of the air compressor, reducing performance. Therefore, the air filter must be replaced regularly.

1. Open the lid on the air filter, then remove the old filter.
2. Replace it with a new filter, then close the lid.

TESTING FOR LEAKS

Make sure all connections are tight. Do not over-tighten.

A small leak in any hose or pipe connection will reduce the air compressor's performance.

To test for small leaks, spray a small amount of soapy water on the area suspected of leaking. If the soap bubbles, replace the broken part.

CLEANING

Clean items with a soft brush, or wipe with a moistened cloth using a biodegradable solvent.

Do not use flammable liquids such as gasoline or alcohol. Always keep parts clean from dirt and dust for better performance.

MAINTENANCE

ADJUSTING THE PRESSURE SWITCH

The pressure switch is used to control the automatic stop-and-start function of the air compressor, ensuring the correct pressure of the compressed air in the tank is maintained.

If the pressure of the compressed air in the air tank is found not to be in the standard range set by the manufacturer, the pressure switch must be adjusted to correctly set the activation valve. (The pressure at which the air compressor will stop running is 9.3 bar, and the pressure at which the air compressor will start running again is 7.2 bar)

Adjust the pressure switch as follows:

1. Open the casing to access the pressure switch.
2. Adjust the setting screw for the maximum pressure. Turning the setting screw clockwise makes the activation pressure higher, so the pressure at which the air compressor stops running will be higher.
3. Adjust the setting screw for pressure difference. Turning the setting screw clockwise makes a larger pressure difference, so the difference between the pressure at which the air compressor starts and the pressure at which the air compressor stops is larger.

Gradual adjustments should make the activation pressures within the range set by the manufacturer.

STORAGE

Before storing for a prolonged period of time:

1. Turn off the power supply.
2. Disconnect the power cord from the power supply.
3. Pull the relief valve and release all the pressure from the air tank.
4. Clean the air compressor to remove all dirt and dust.
5. Cover the air compressor with a cover to protect the unit from dust and moisture.
6. Do not stack or store items on top of or around the air compressor.
Damage could occur.

TROUBLESHOOTING

TROUBLESHOOTING CHART

If you are experiencing a problem that is not listed in this chart, or have checked all the possible causes listed and you are still experiencing the problem, see your authorized dealer.

Problem	Possible causes	Remedies
Pressure drop in the tank.	Air leaking at connections.	Let the air compressor build pressure in the tank to the maximum pressure if possible. Brush soapy water on air connections and look carefully for air bubbles. Tighten leaky connections. If the problem persists, contact your dealer for further advice.
The compressor stopped and does not start.	Overload cutout operated because of motor overheating.	Check that the main voltage corresponds to specifications. An extension cord that is too thin or too long can cause a voltage drop and cause the motor to overheat. Allow the motor to cool down. Use heavy duty extension cords. Ensure that the compressor is plugged into a socket as close as possible to the consumer unit or fuse box.
The compressor stopped and does not start. The motor does not start and makes a humming noise.	Motor windings are burned out.	Contact Customer Support.
	Capacitor is burned out.	Replace capacitor.
The motor does not start or starts slowly.	Low voltage supply to the motor.	Check that the main voltage corresponds to specifications. An extension cord that is too thin or too long can cause a voltage drop and cause the motor to overheat. Allow the motor to cool down. Use heavy duty extension cords. Ensure that the compressor is plugged into a socket as close as possible to the consumer unit or fuse box.

TROUBLESHOOTING

The compressor is noisy with metallic clangs.	Compressor head gasket is broken or valve is faulty.	Stop the compressor and contact your dealer.

TROUBLESHOOTING

Problem	Possible causes	Remedies
The compressor does not reach the maximum pressure.	Compressor head gasket broken or valve faulty.	Stop the compressor and contact your dealer.
The compressor doesn't seem to provide as much air as it did when new and/or the compressor cuts off within a much shorter time period.	The pressure switch needs adjusting.	Stop the compressor and contact your dealer.
	The tank is full of water due to condensation.	Open the ball valve and release the pressure. Open the drain valve and release the water within the tank.
The motor pump unit does not stop when the tank pressure reaches its maximum working pressure (9.3 bar or 135 PSI) and the safety valve vents air.	Pressure switch defective or needs adjusting.	Stop the compressor immediately and contact Customer Support.

UNIT BREAKDOWN

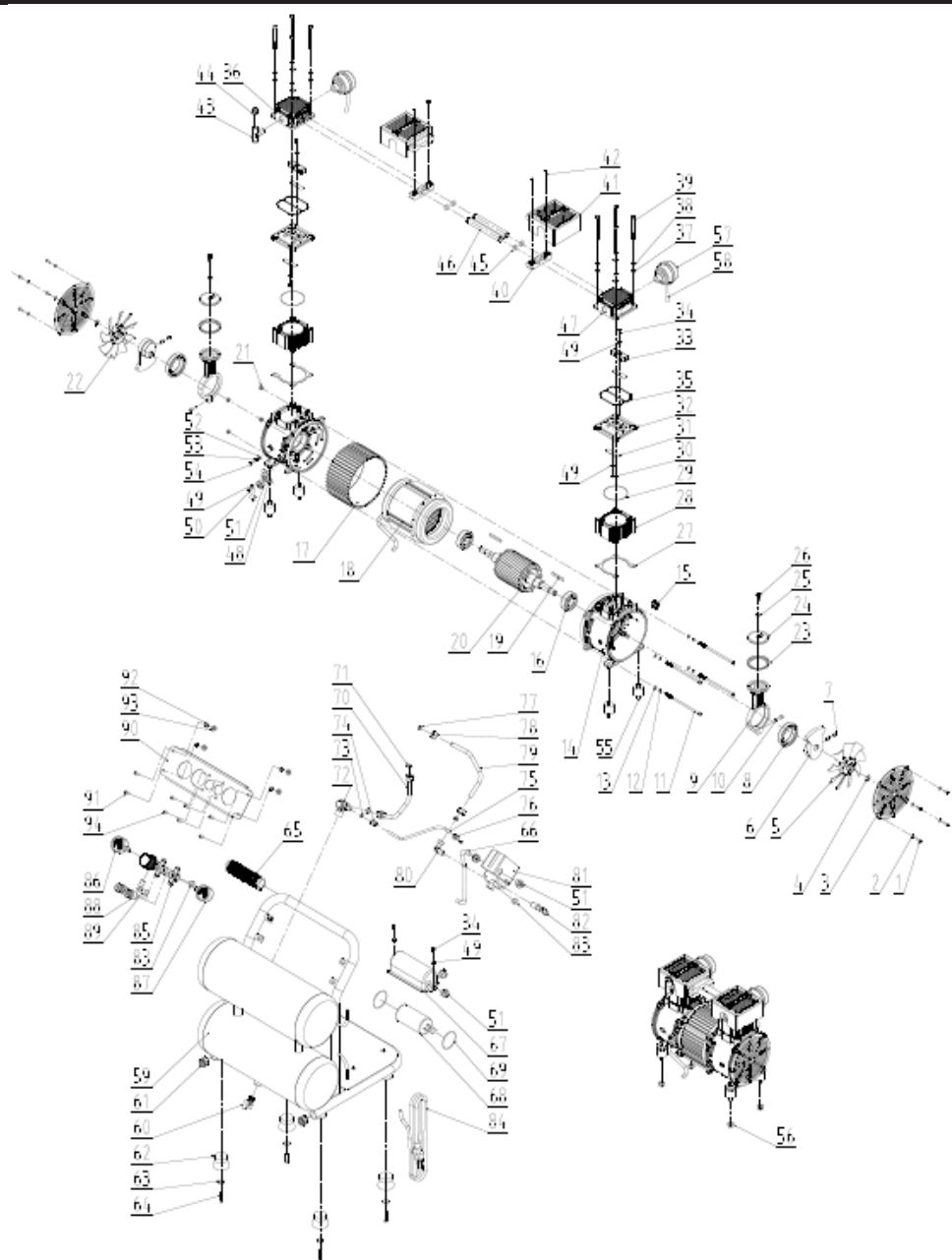

UNIT BREAKDOWN

REF #	MAIN DESCRIPTION	QTY	PART #
1	Cross recessed pan head bolt M4*12	8	GB/T818
2	Flat washer ϕ 4	8	GB/T97.1
3	Crankcase cover	2	MWL20B4P-12A
4	Circlip	2	GB/T894.1
5	Fan 1	1	MWL20B4P-11A
6	Crankshaft	2	MWL20B4P-02C
7	Hex socket screw M8*8	4	GB/T80
8	Bearing	2	GB/T276
9	Connecting rod	2	MWL20B4P.01-01A
10	Hex socket cap screw M5*20	2	GB/T70.1
11	Hex bolt M5*132	4	M20B-06C
12	Spring washer ϕ 5	4	GB/T93
13	Flat washer ϕ 5	4	GB/T97.1
14	Crankcase	2	MWL20B4P-05E
15	Plastic plug	1	MWL20B4P-13A
16	Bearing	2	GB/T276
17	Stator sleeve	1	MWL20B4P-08B
18	Stator	1	MWL25B4P.02
19	Flat key	2	GB/T1567
20	Rotator	1	MWL25B4P.01
21	Hex nut with flange M5	4	GB/T6177.1
22	Fan 2	1	MWL20B4P-11B
23	Piston ring	2	MWL20B4P.01-03A
24	Piston cap	2	MWL20B4P.01-02A
25	Bonded washer ϕ 6	2	JB982
26	Hexagon socket bolt with pattern M6*16	2	MW15BG.04-01
27	Cylinder gasket	2	MWL20B4P-17
28	Cylinder	2	MWL20B4P-01C
29	Cylinder seal	2	MWL20B4P-14A
30	Cross recess pan head screw M4*6	2	GB/T823
31	Valve	4	MWL20B4P-03
32	Valve plate	2	MWL20B4P-04A

UNIT BREAKDOWN

33	Valve holder	2	MWL20B4P-07
34	Cross recess pan head screw m4*8	4	GB/T818
35	Cylinder cap sealing	2	MWL20B4P-15
36	Cylinder	1	MWL20B4P-06
37	Flat washer $\phi 6$	8	GB/T97.1
38	Spring washer $\phi 6$	8	GB/T93
39	Hex bolt M6*70	8	MWL20B4P-18
40	Cylinder cap holder	2	MWL20B4P-26
41	Cylinder cap shroud	2	MWL20B4P-25A
42	Cross recessed pan head tapping screw st3.9*19	2	GB/T845
43	T fitting	1	AC1506-15F2
44	Cold start valve	1	AC2520BDM.01
45	Seal	4	MWL20B4P-16
46	Air tube	2	MWL20B4P-09B
47	Cylinder cap 2	1	MWL20B4P-06C
48	Cable clip holder	1	ACWL2598BIM4P-01
49	Flat washer $\phi 4$	6	GB/T97.1
50	Cross recess pan head screw M4*5	2	GB/T818
51	Cable clip	5	7N-2
52	Hex nut M4	1	GB/T6170
53	Serrated lock washers external teeth M4*12	1	GB/T862.2
54		1	GB/T818
55	Rubber cushion	4	MWL20B4P.04B
56	Type 1 non-metal insert hexagon nut M8	4	GB/T6183.1
57	Air filter	2	AC1506.14R
58	Muffler tube	2	MW05B4P-26A
59	Tank assembly	1	CWD-16/1.0-00
60	Drain valve	1	ACW2506BG4P.13B
61	Rubber plug	2	AC2520BDM-05A
62	Rubber foot	4	AC1506-09J
63	Flat washer $\phi 5$	4	GB/T5287-85
64	Hex socket bolt with cylindrical head M5*23	4	GB/T70.1-2000
65	Rubber grip	1	CWD-20/0.7-08B

UNIT BREAKDOWN

66	Cord	0.4	ACW2506BG4P.FJ.01
67	Capacitor case	1	ACWL2598BIM4P-03C
68	Capacitor	1	M20B.04M
69	O ring $\Phi 50.5 \times \Phi 2.5$	2	ACW2506BG4P.FJ-02
70	Exhaust tube assembly	1	ACWL1008LBGM4P-02E
71	Sealing	2	MW05B4P-15A
72	Check valve	1	AC1506.09-01D
73	Small ferrule	2	AC1506.08-03A
74	Tube nut G1/8	1	AC1506.08-01B
75	Aluminum tube	0.009	$\phi 6 \times 1 \text{mm}$
76	Tube nut	1	AC1506.08-01D
77	Big ferrule	2	AC1506.11-03B
78	Tube nut G3/8	2	AC1506.11-01B
79	Nylon tube $\phi 10 \times 1.5$	0.2	$\phi 10 \times 1.5$
80	Elbow	1	ACW2016BDM-10B
81	Pressure switch	1	ACW2016BDM.03N
82	Safety valve	1	AC1506.02AE
83	Rubber plug	2	AC2016BD-13B
84	Cord	1	AC2030BH-IFJ-002E1
85	Regulator	1	AC2016BDM-I.02-03C
86	Pressure gauge	1	AC2016BDM-I.03C
87	Pressure gauge	1	AC2016BDM-I.01E
88	coupler	2	AC1506.06E
89	Elbow	1	ACW2016BDM-10D
90	Control panel	1	AC2016BDM-I-05C
91	Hex bolt M6*14	4	ACW05038BGM4P-03
92	Serrated lock washers external teeth 6	4	GB/T862.2
93	K cap nut	4	ACWL1008LBGM4P-08
94	Hex bolt M5*14	4	GB/T70.2

WARRANTY

Bissett Fasteners Limited warrants that each new product will be free of any manufacturer defects for a period of 2 years. This warranty covers the air tank, engine, and air pump. Warranty applies to the original purchaser of the product and cannot be transferred.

This warranty does not cover normal wear items, including but not limited to: seals, packings, valves, etc. Warranty also does not include normal maintenance like oil changes, filters or valve adjustments. Nor does it include misuse of product. Warranty approval is at the sole discretion of Bissett Fasteners Limited.

In no event shall Bissett Fasteners Limited be liable for any indirect, incidental or consequential damages from the misuse of the product. This disclaimer applies both during and after the term of this warranty. Bissett Fasteners Limited disclaims liability for any implied warranties, including implied warranties of merchantability and fitness for a specific purpose, after the applicable term of this warranty.

**If you need assistance with the assembly
or operation of your Compressor, please call**

604-545-0252